

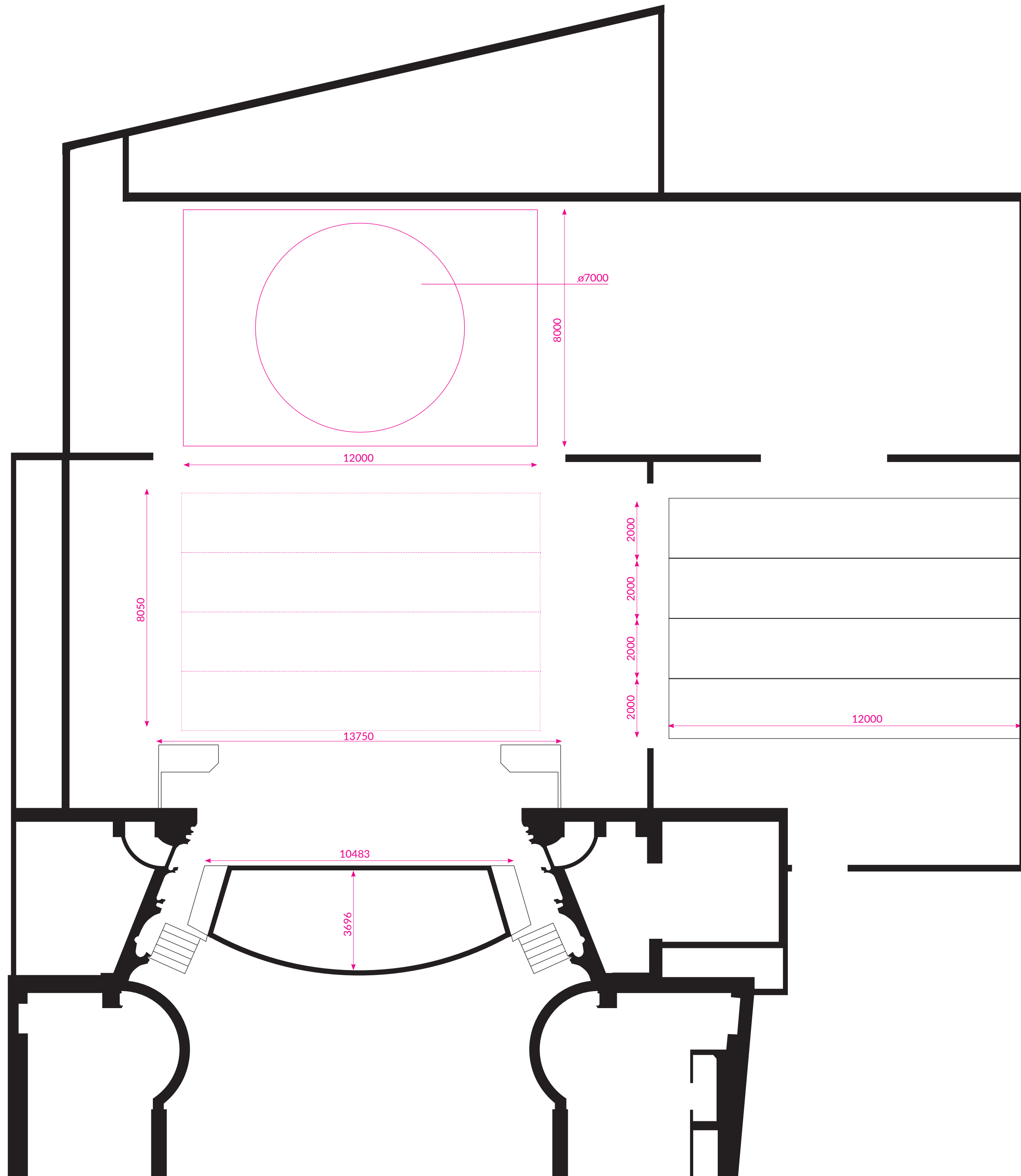

**R & J** SCENOGRAFIA

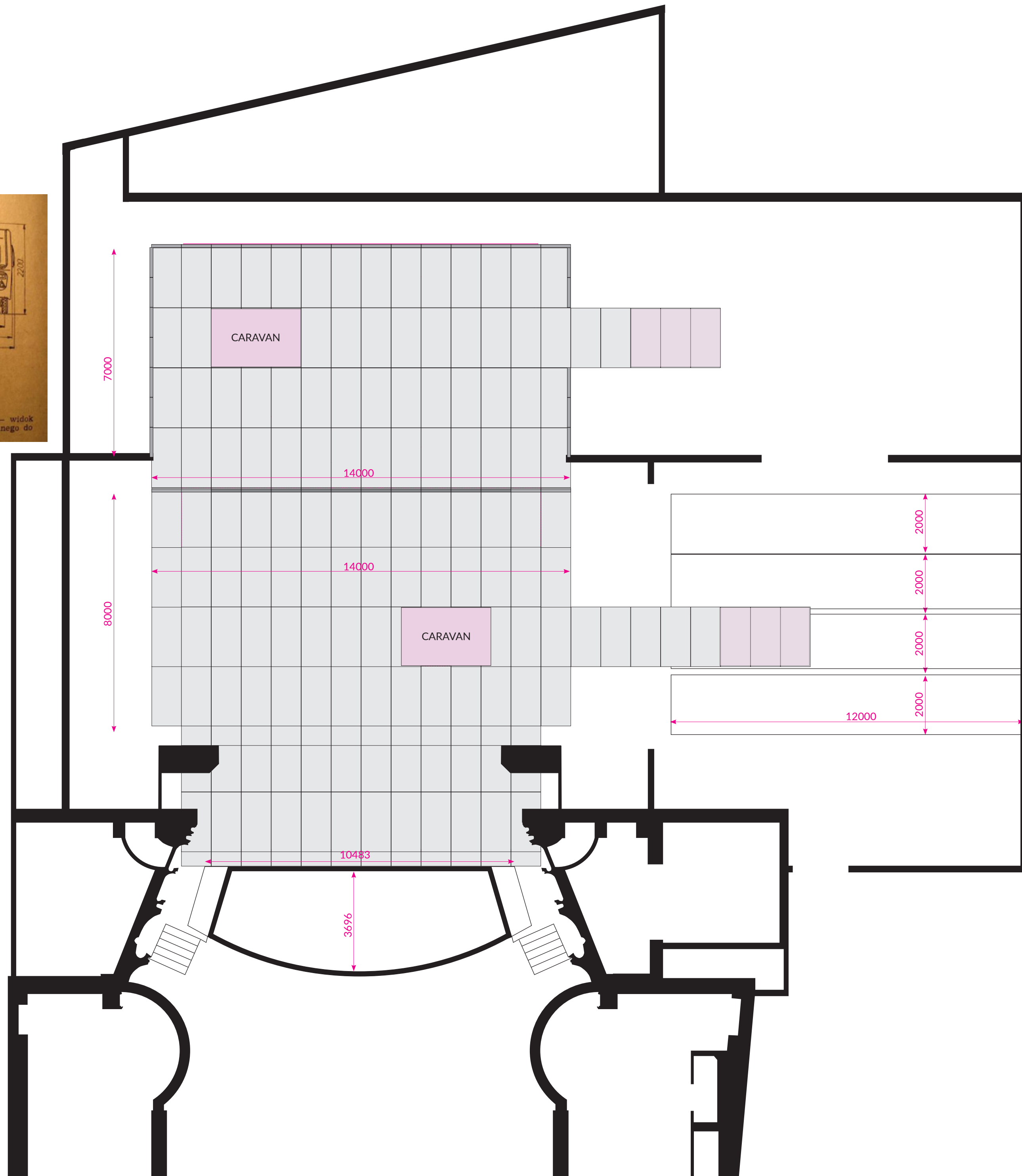

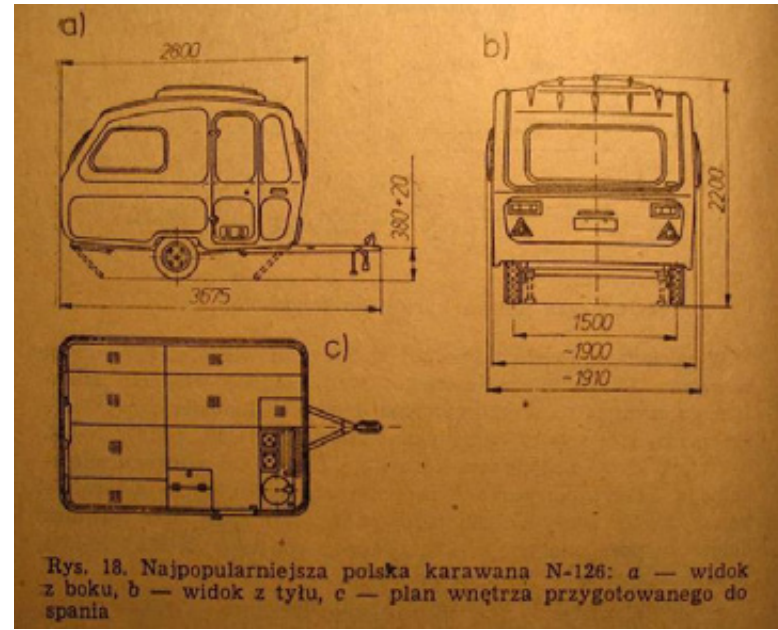

**SCENA** - RZUT Z GÓRY  
UKŁAD SCENOGRAFII

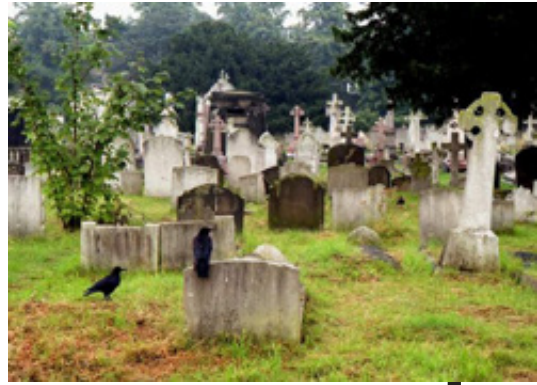
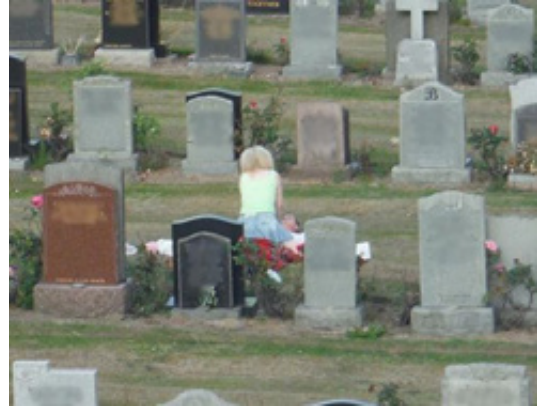

ŚCIANY

USTAWIENIE NAGROBKÓW

MIEJSCE PARKOWANIA PRZYCZEPY  
I OBIEKTU Z ROŚLINAMI

RUCHOMA ŚCIANA TYLNA

WYKŁADZINA PVC Z NADRUKIEM  
~310M2

MIEJSCE PARKOWANIA PRZYCZEPY  
I OBIEKTU Z ROŚLINAMI

USTAWIENIE NAGROBKÓW  
Z PŁYTA

PODŁOGA POD KĄTEM 3,5°  
BAZA: PODEST 200X100  
50 SZTUK WRAZ Z NOGAMI ALU

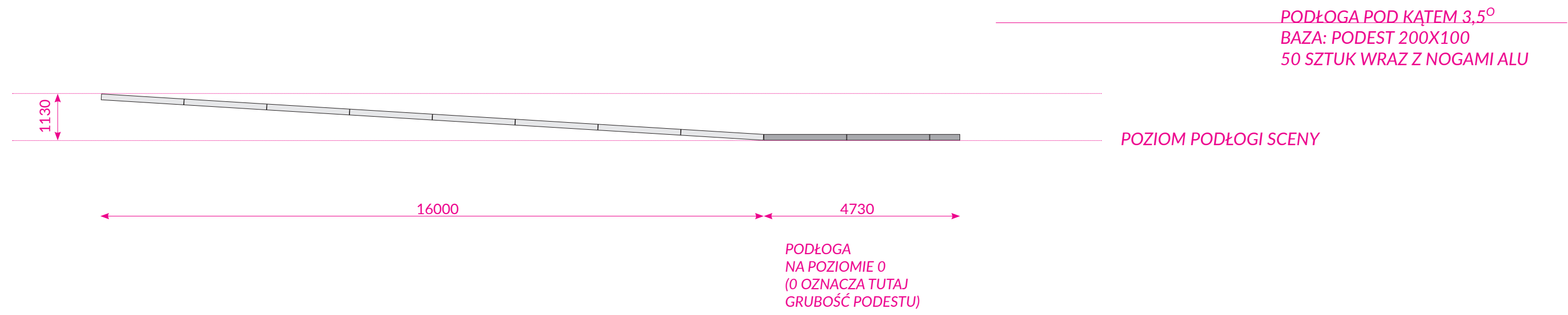

**WERSJA ALTERNATYWNA**

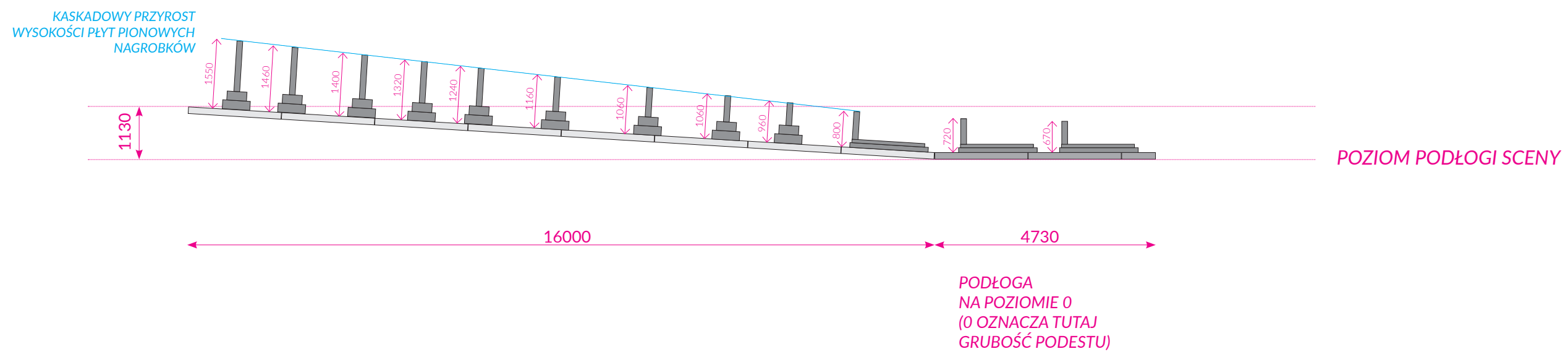
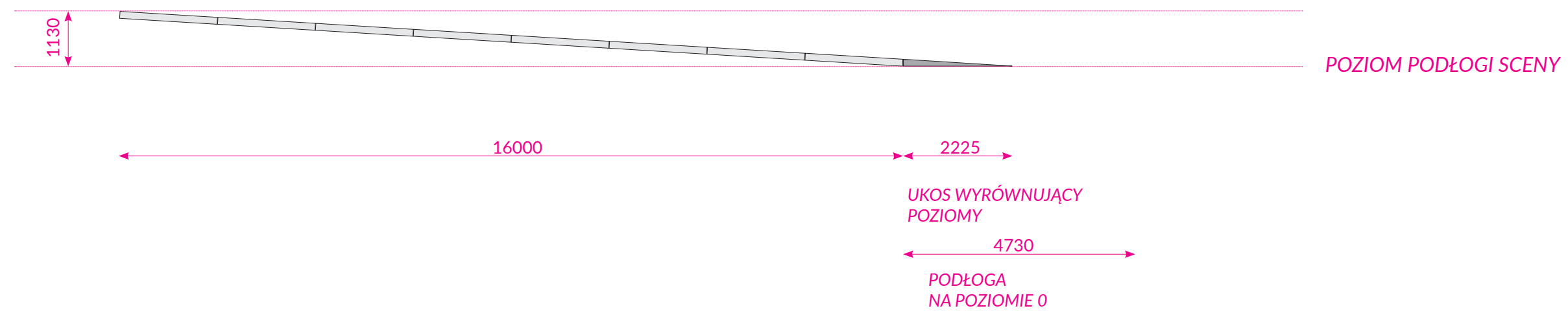

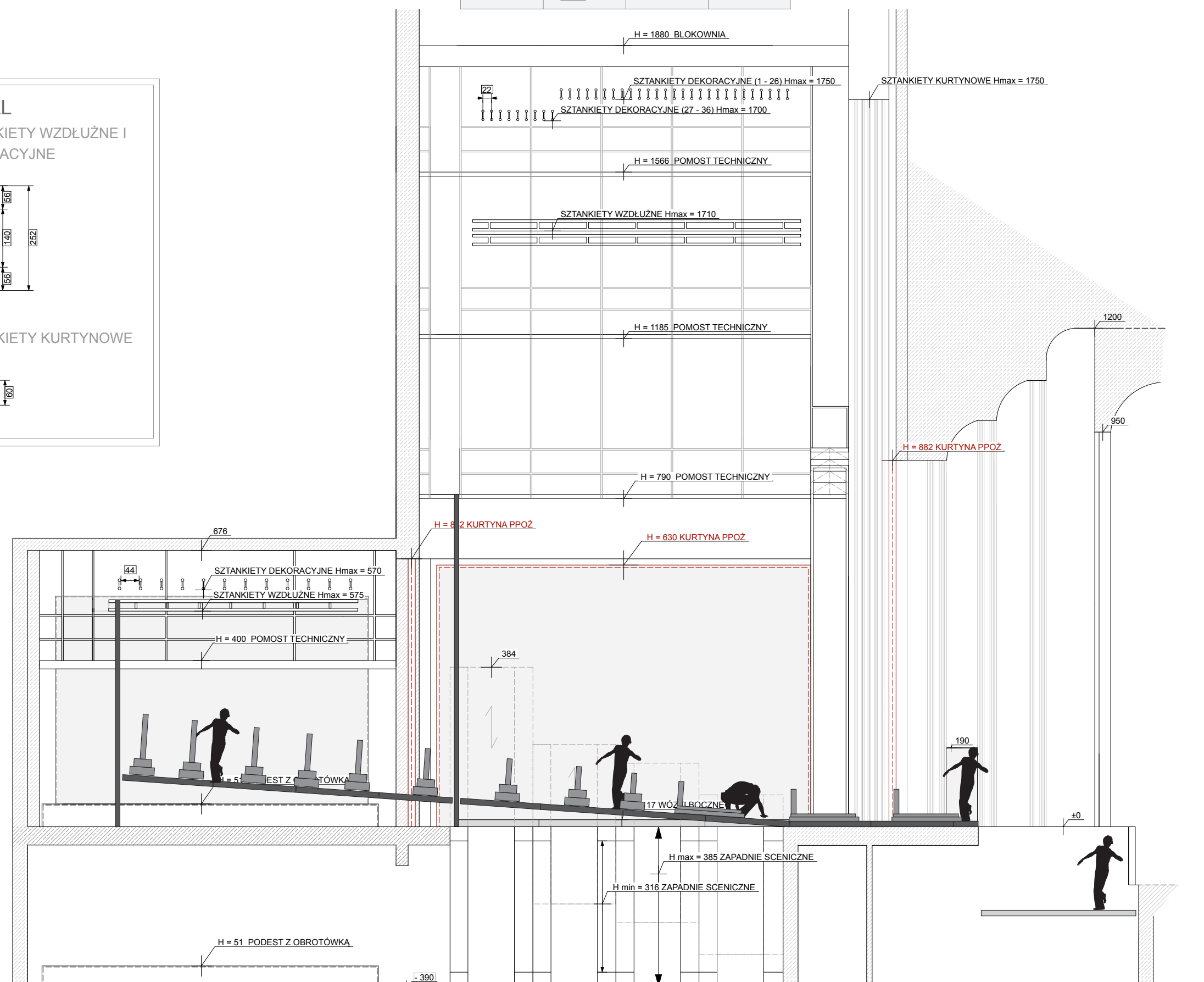
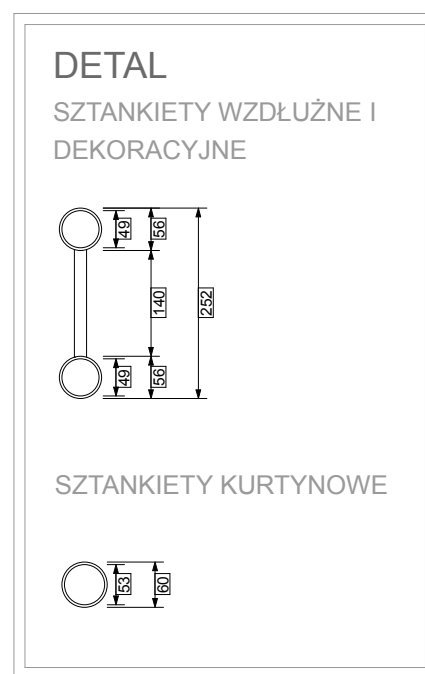
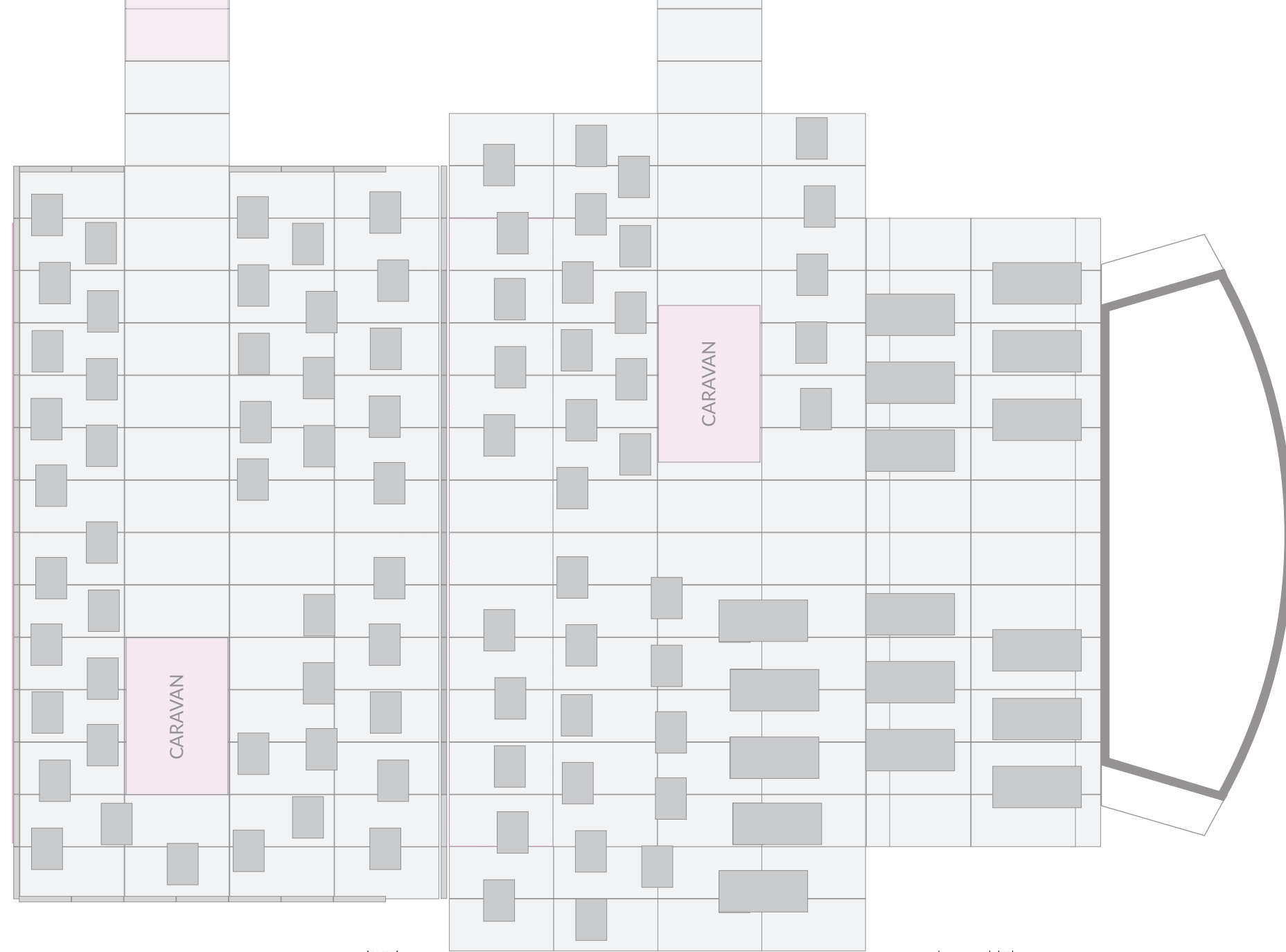











**2 PRZYCZEPY KAMPINGOWE**  
- POWINNY BYĆ LUSTRZANYM  
ODBICIEM: KONIECZNA PRZERÓB-  
KA JEDNEJ Z NICH

**UWAGA!**  
PODWOZIE PRZYCZEP MUSI BYĆ  
DOSTOSOWANE DO POCHYLEŃ  
POSADZKI

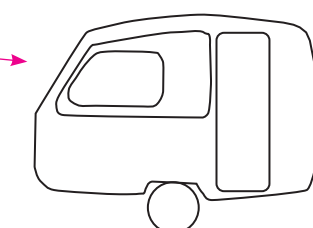

WŁAŚCIWA STRONA Z DRZWIAMI

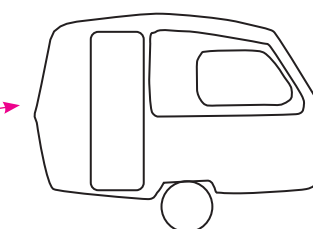

PRZEROBIONA STRONA TYLNA  
PRZYCZEPY - DOROBIONE DRZWI

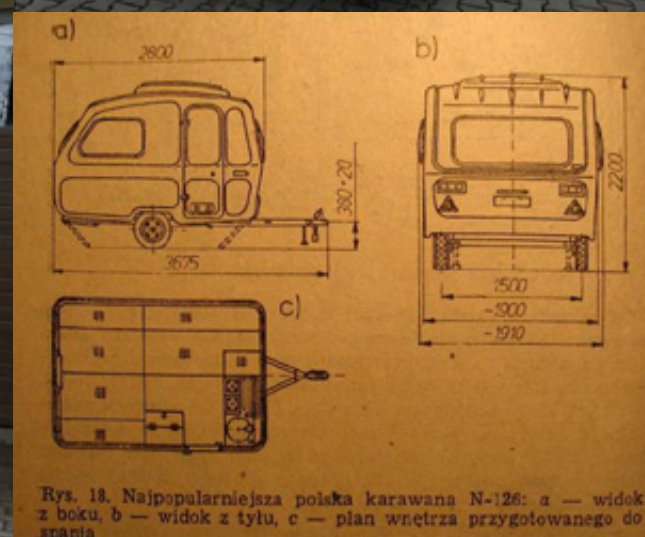

Rys. 18. Najpopularniejsza polska karawana N-126: a — widok z boku, b — widok z tyłu, c — plan wnętrza przygotowanego do spania



**OBIEKT Z ROŚLINAMI:**  
ZAMKNIĘTA PRZESTRZEŃ  
POLIWĘGLANEM TRANSPARENTNYM  
+ ROŚLINNOŚĆ - CAŁOŚĆ UMIESZCZONA  
NA WÓZKU TRANSPORTOWYM



### WÓZEK TRANSPORTOWY:

1200X800 MM  
KOŁA 200 MM  
NOŚNOŚĆ 500 KG

### DOSTAWCA

[https://www.b2b-partner.pl/wozek-platformowy-platforma-1200-x-800-mm-nosnosc-500-kg-kola-200-mm-z-czarna-guma/?gad\\_source=1&gclid=CjwKCAjw1emzBhB8EiwAHwZZxUENGv9gbvW9kEK4QHh32LGfySssSr0dTuDTTz4gZZ0sY6TZdBpTRhoCWxgQAvD\\_BwE](https://www.b2b-partner.pl/wozek-platformowy-platforma-1200-x-800-mm-nosnosc-500-kg-kola-200-mm-z-czarna-guma/?gad_source=1&gclid=CjwKCAjw1emzBhB8EiwAHwZZxUENGv9gbvW9kEK4QHh32LGfySssSr0dTuDTTz4gZZ0sY6TZdBpTRhoCWxgQAvD_BwE)

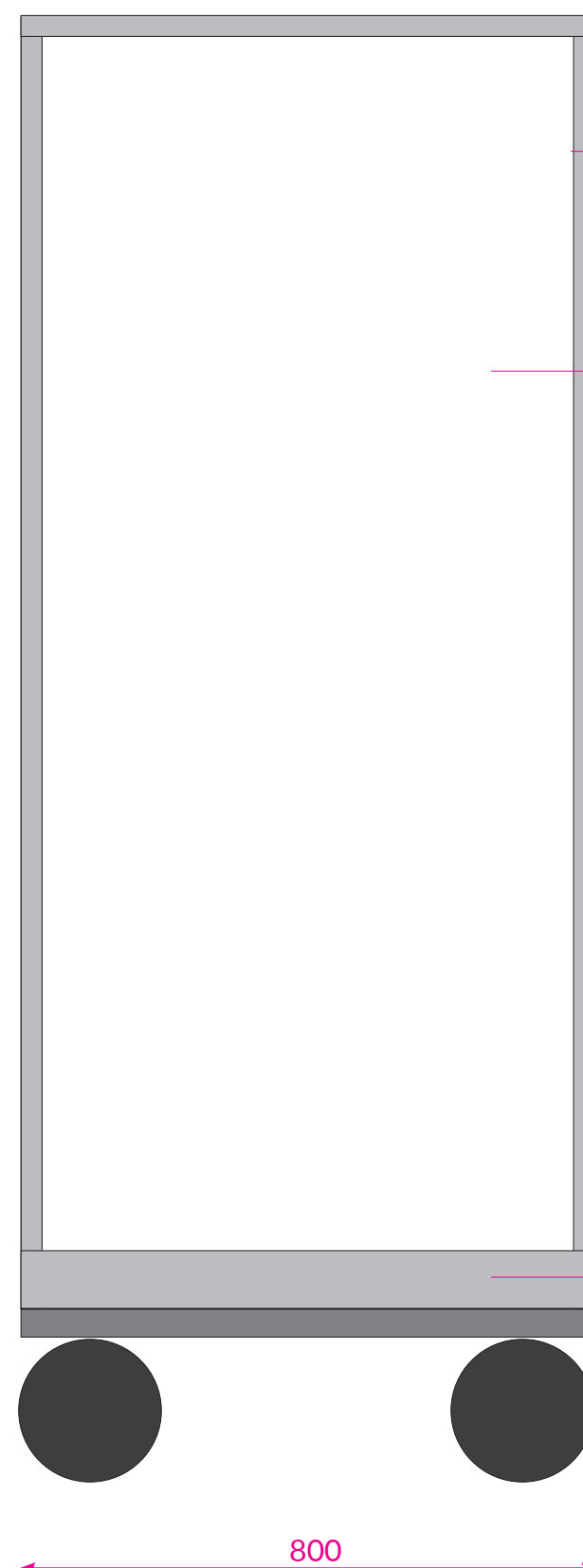
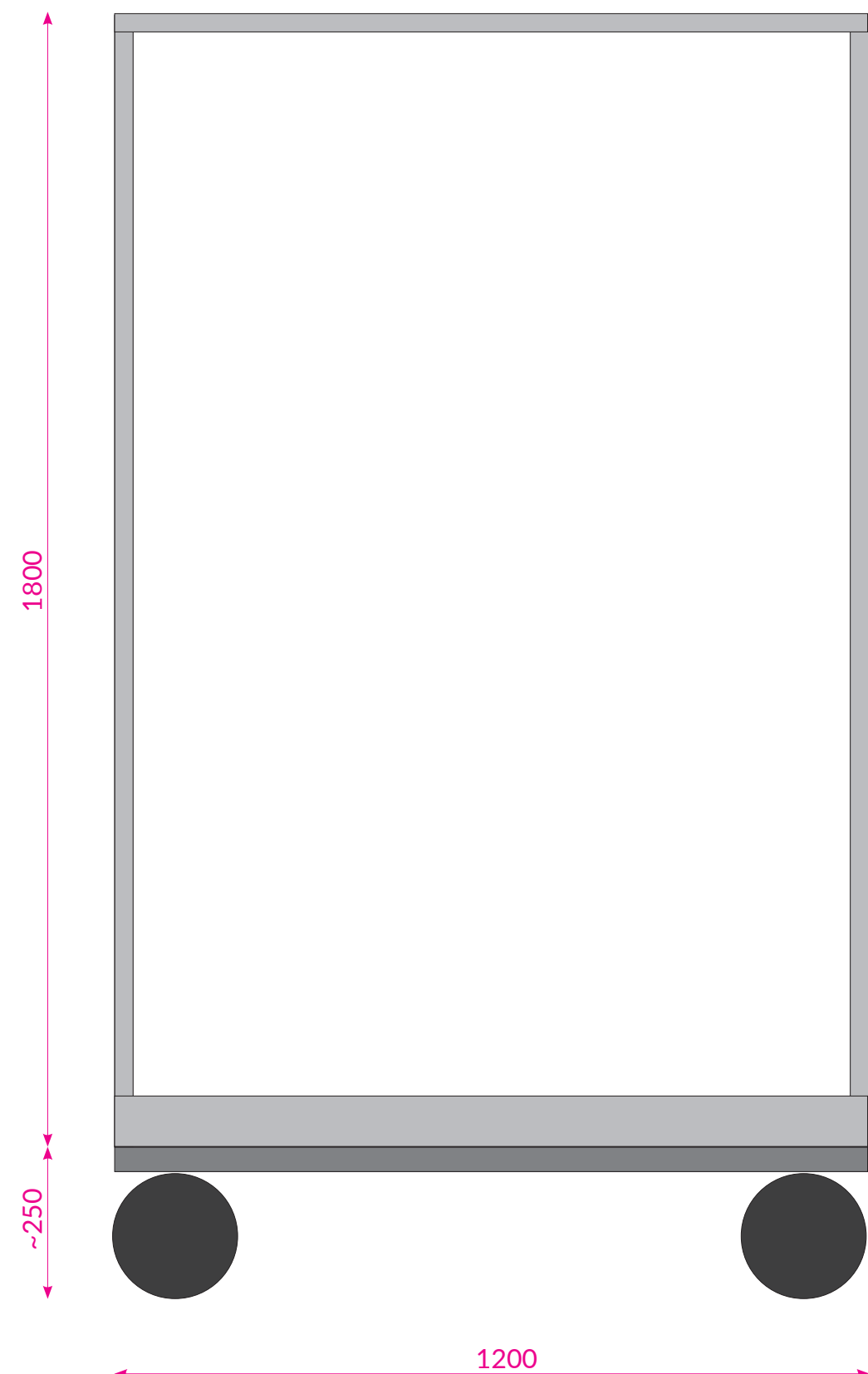

KĄTOWNIK STAL  
30X30 MM

POLIWĘGLAN TRANSPARENT  
~8-10 MM  
WYPEŁNIENIE: ŚCIANY PLUS SUFIT

OPASKA BLACHA STAL  
~0,5-1 MM  
WYSOKOŚĆ: 80 MM

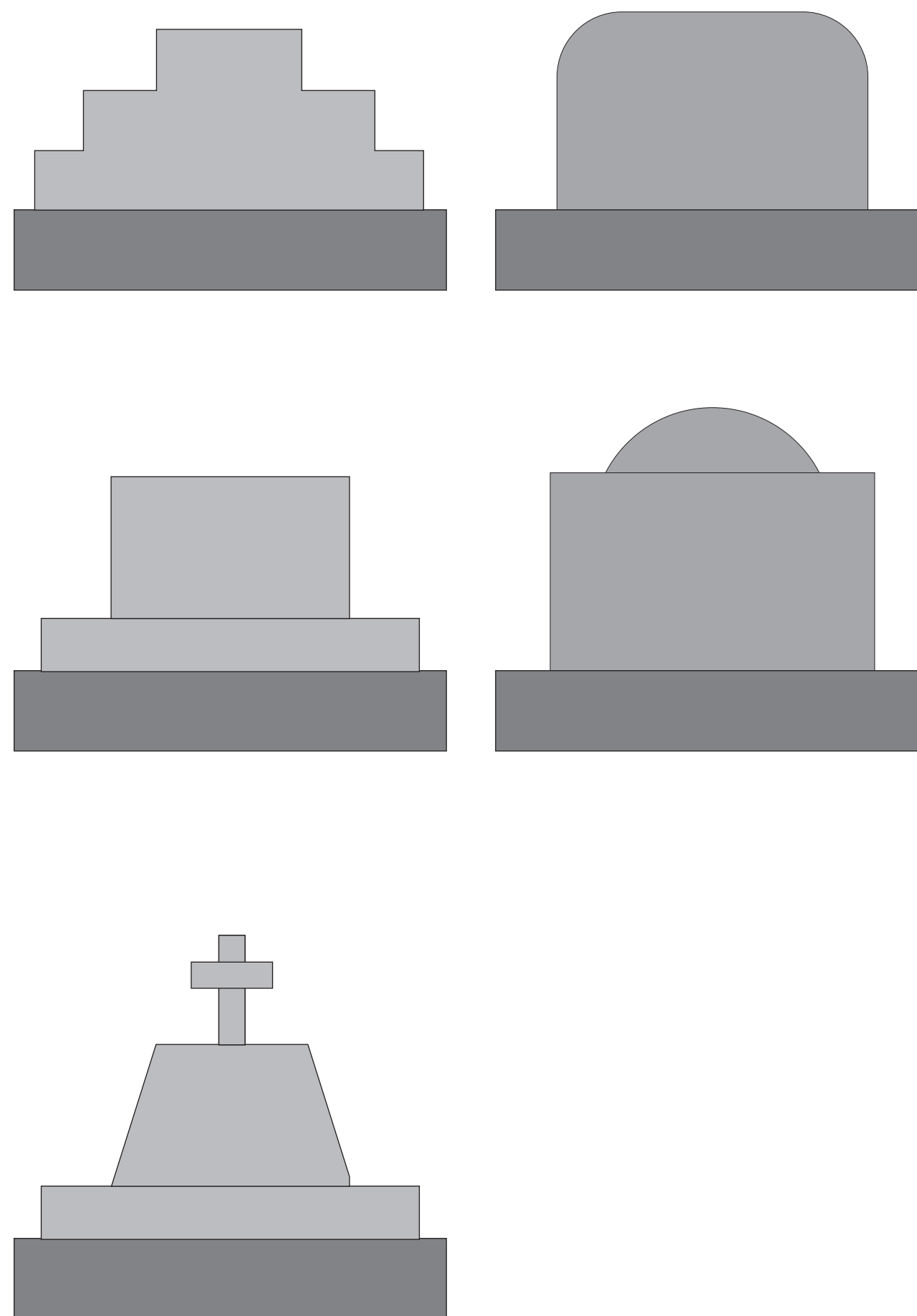
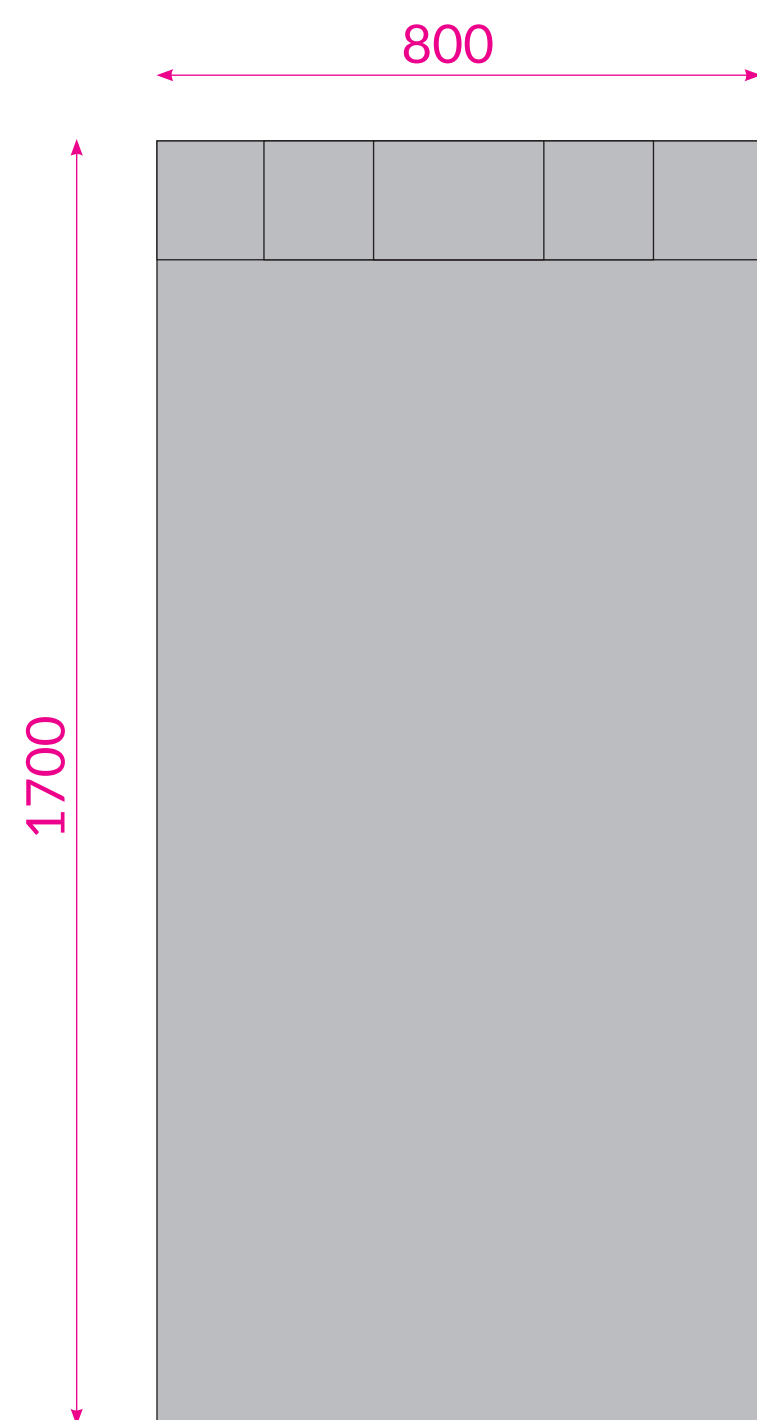
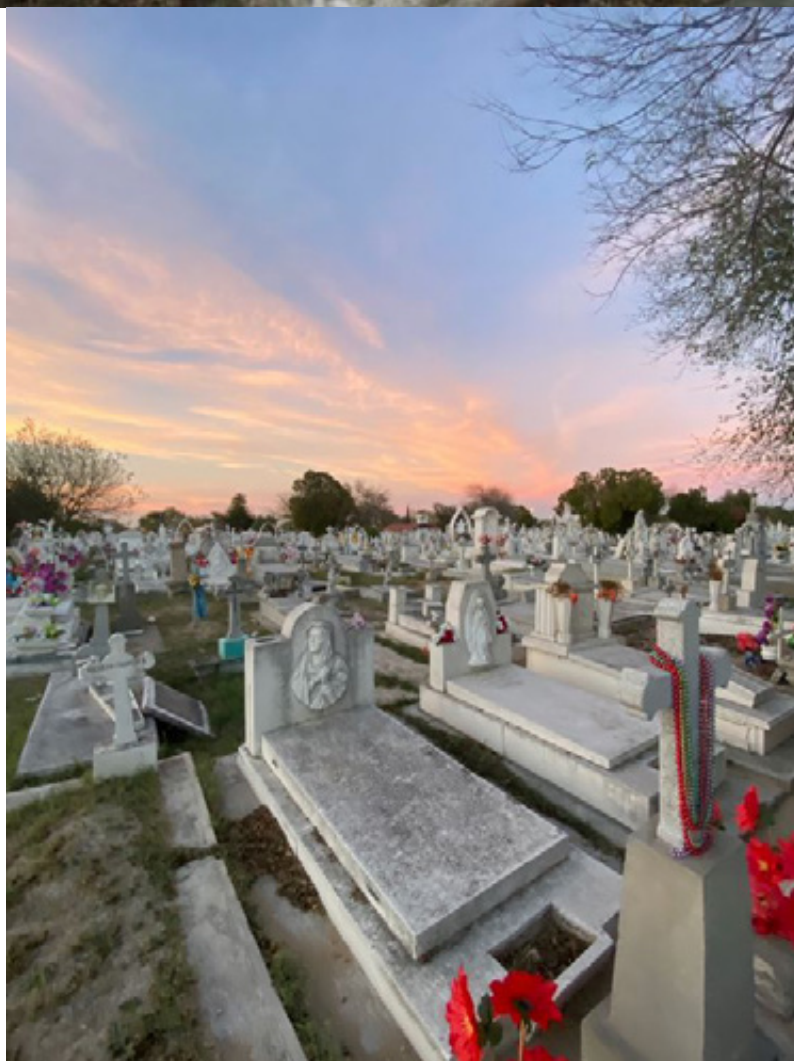
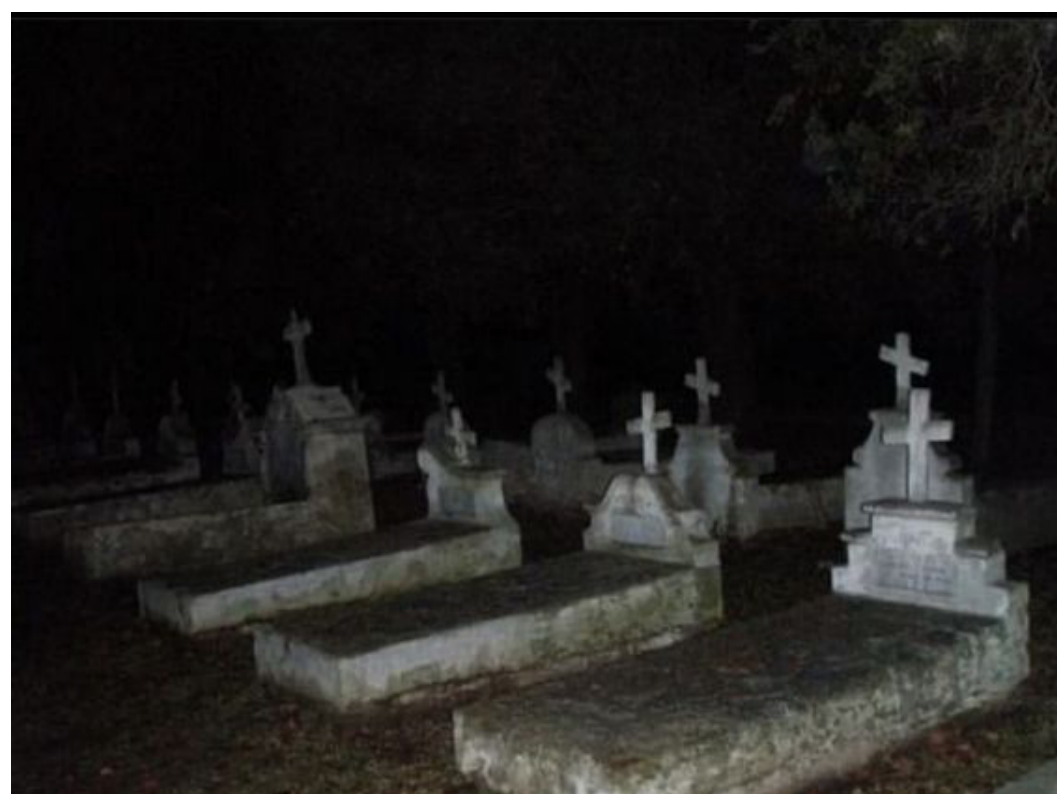

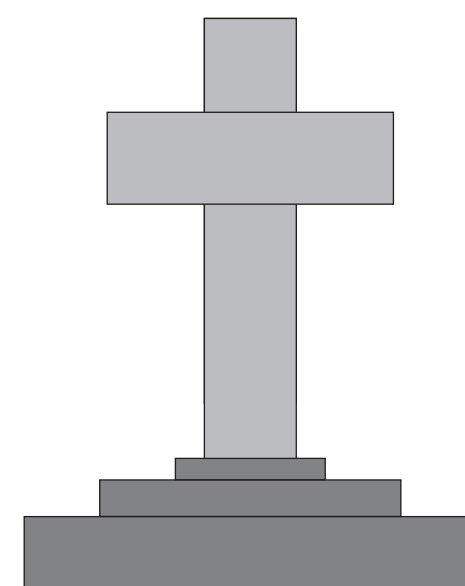
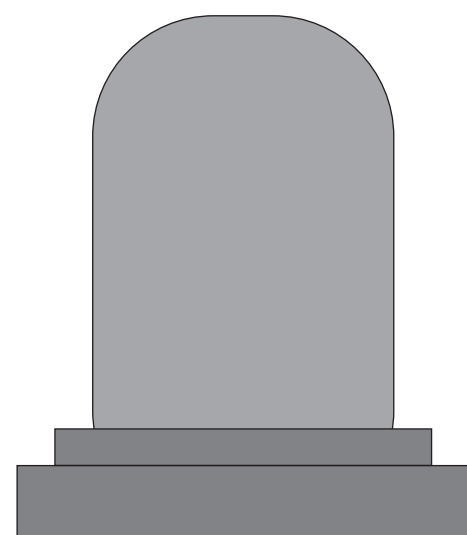
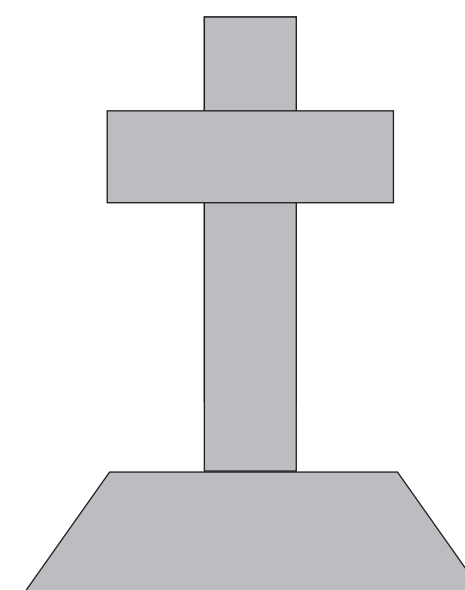
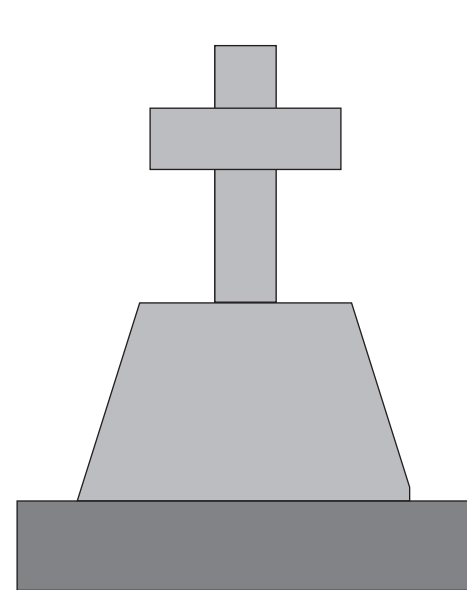



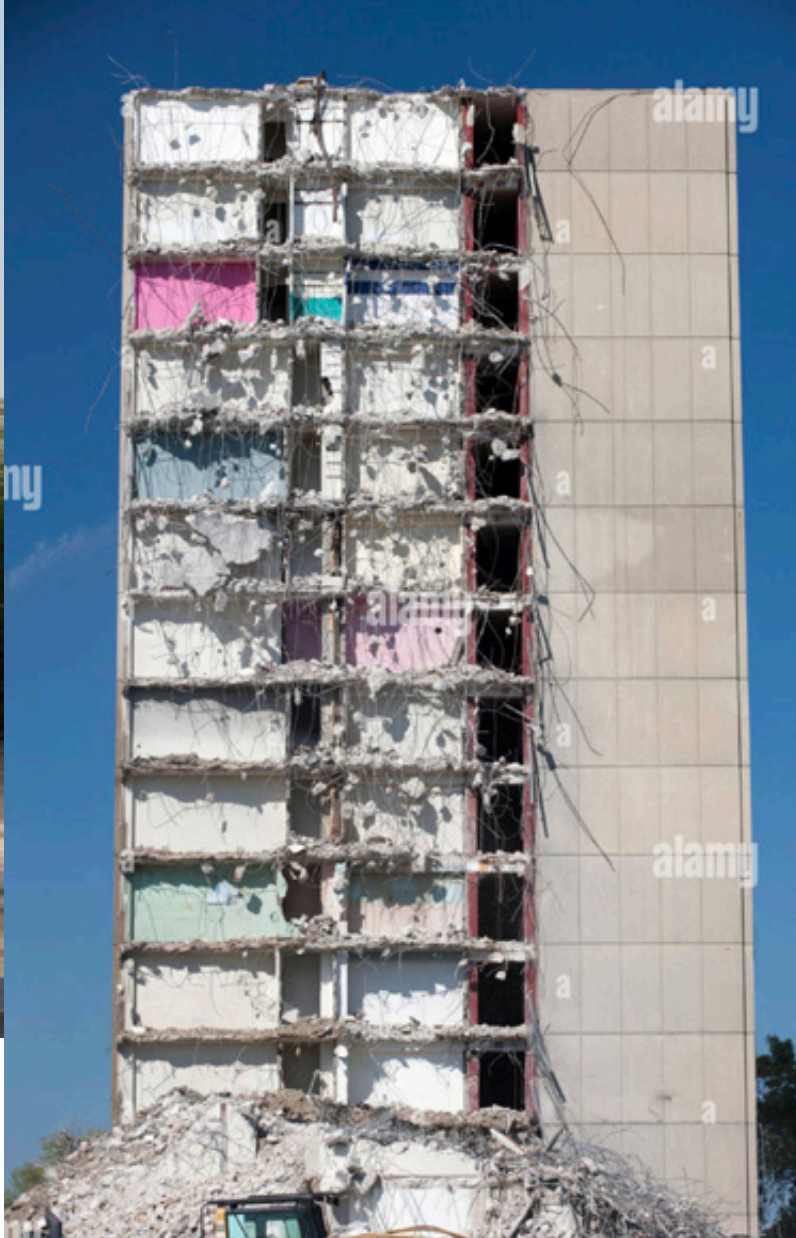



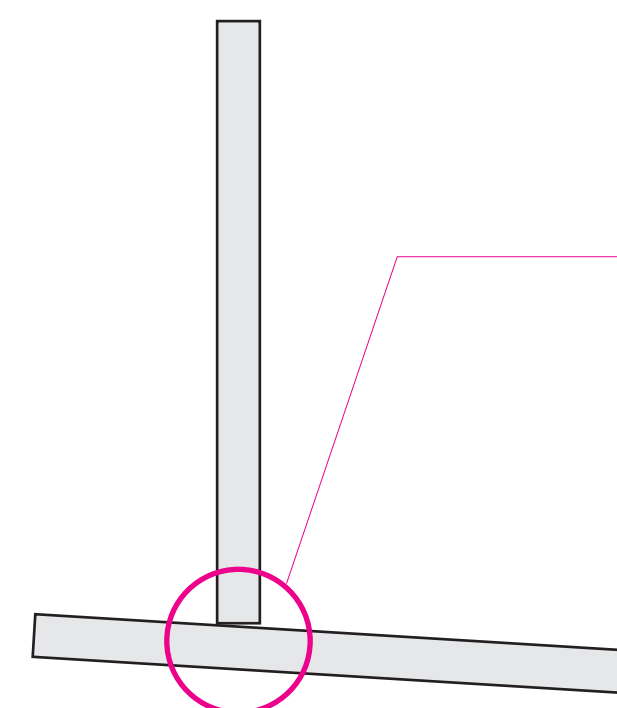
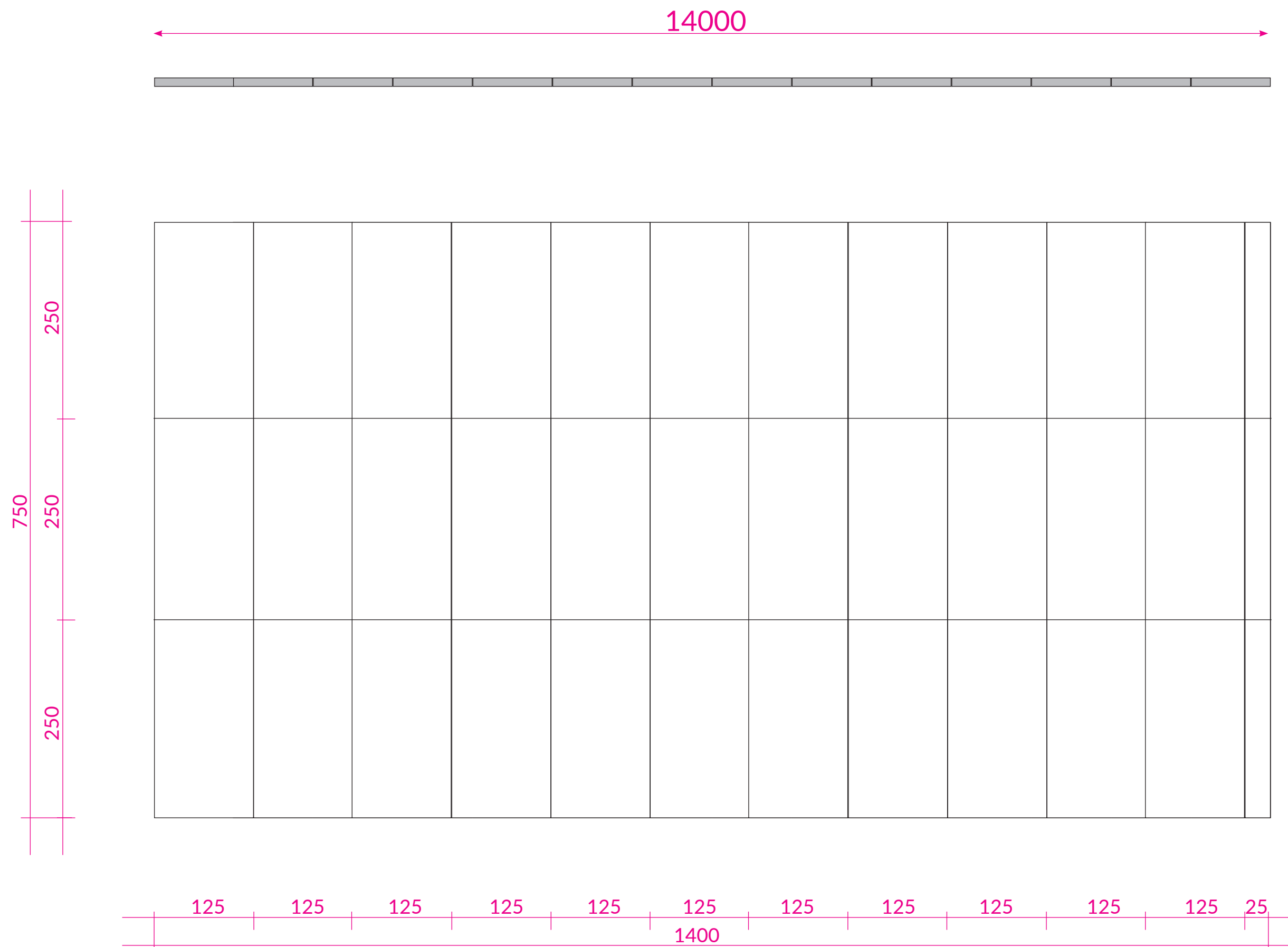

**ŚCIANA**  
DOLNA KRAWĘDŹ ŚCIANY POWINNA  
BYĆ DOSTOSOWANA DO POCHYLONEJ  
PODŁOGI TAK ABY ZNIWELOWAĆ SZCZELINĘ

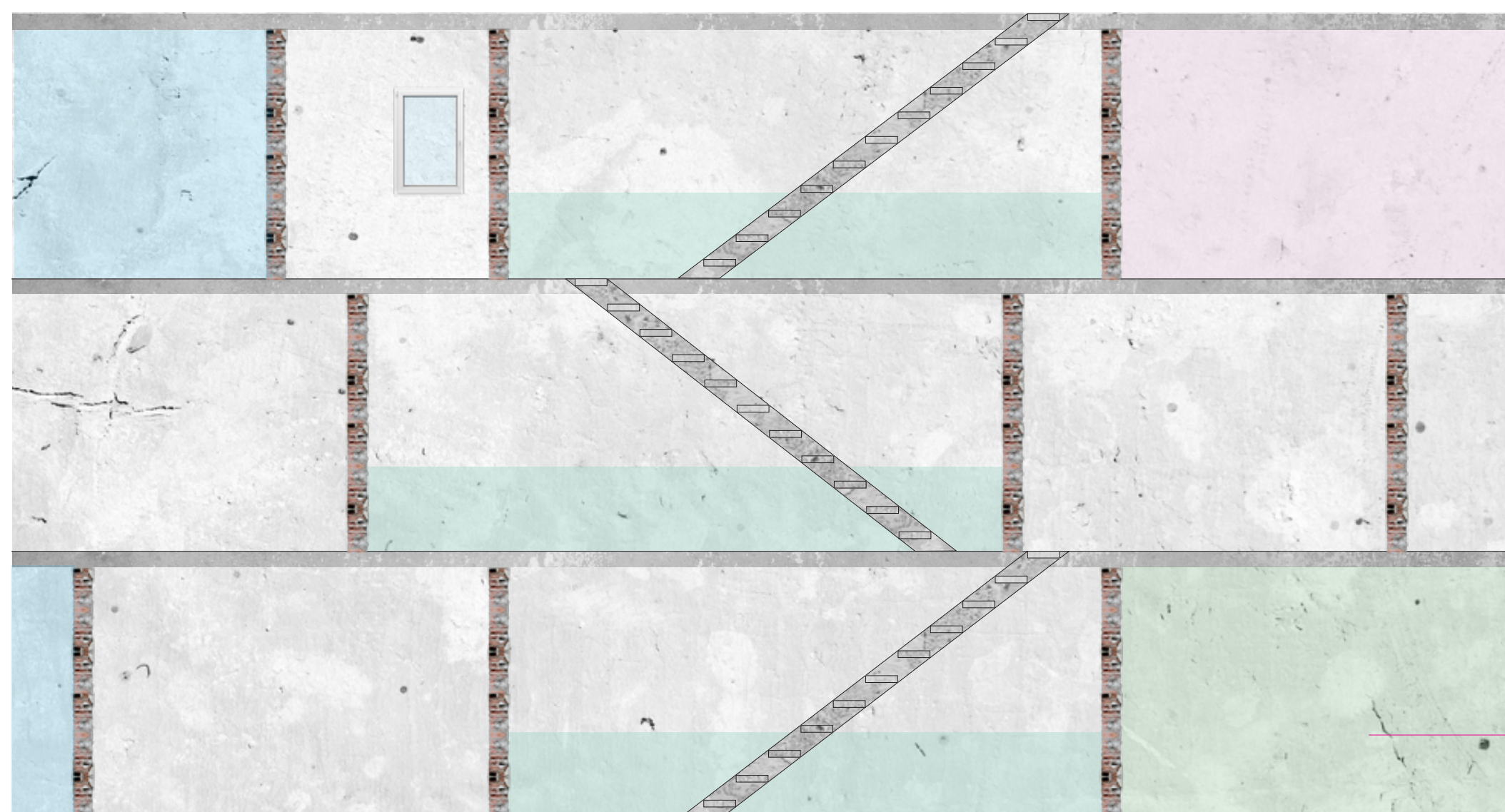

**ŚCIANA**  
Z ZAZNACZONYMI ELEMENTAMI ARCHITEKTURY PO WYBURZENIU BUDYNKU:  
FRAGMENTY TAPET, CIĄGÓW KOMUNIKACYJNYCH ITD.  
OKNO W NAJWYŻSZEJ KONDYGNACJI

**UWAGA!**  
ŚCIANA PODNOSZONA NA SZTANKIECIE

**SCENOGRAFIA**  
ŚCIANY TYLNE

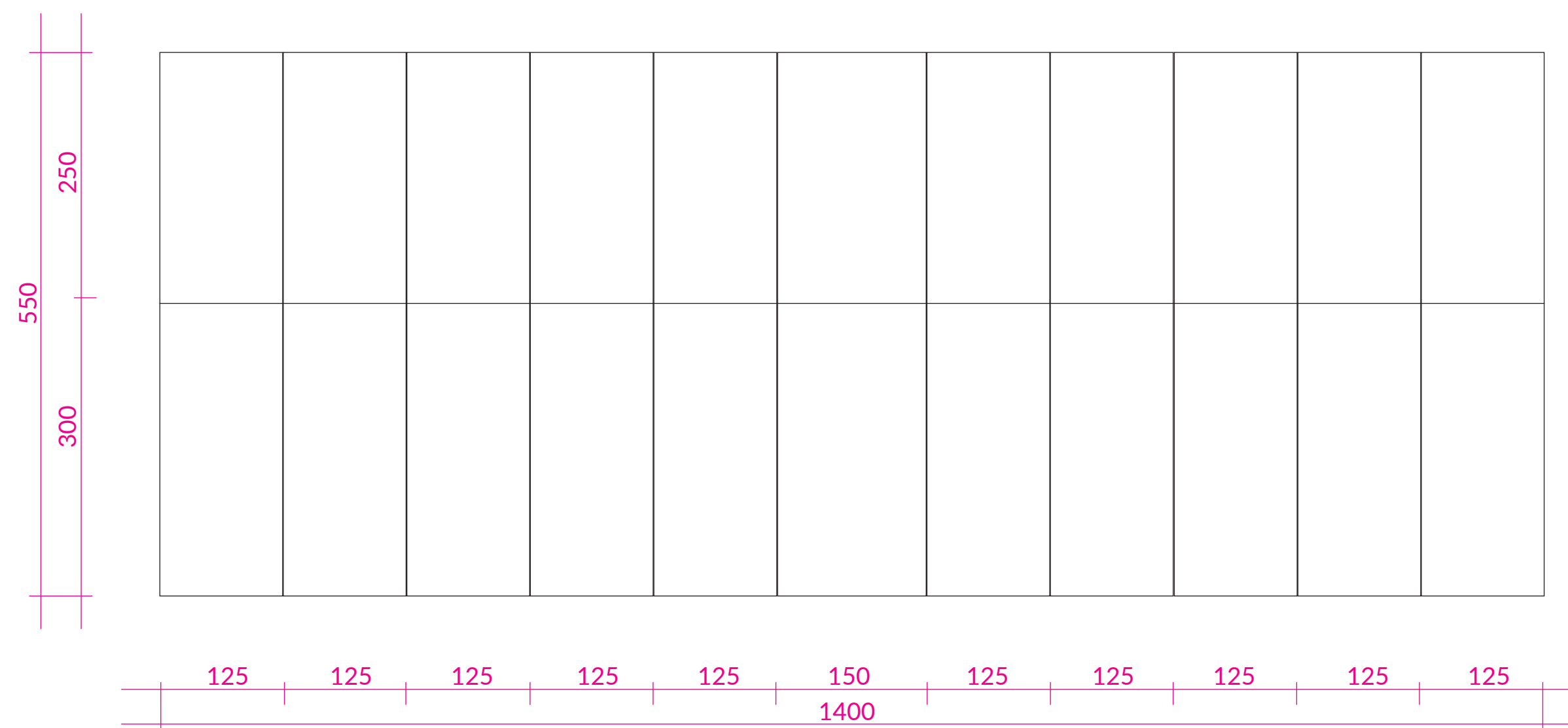
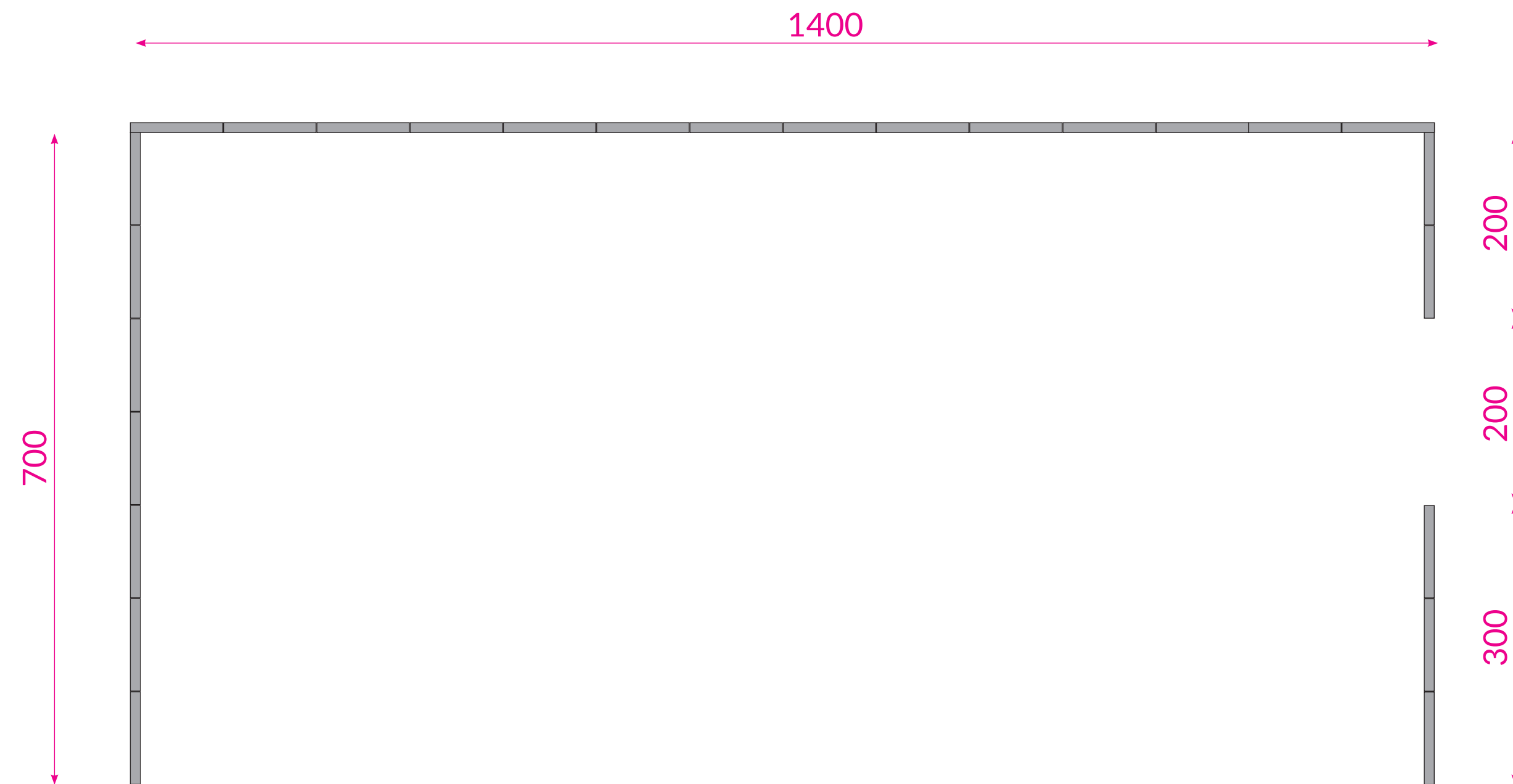

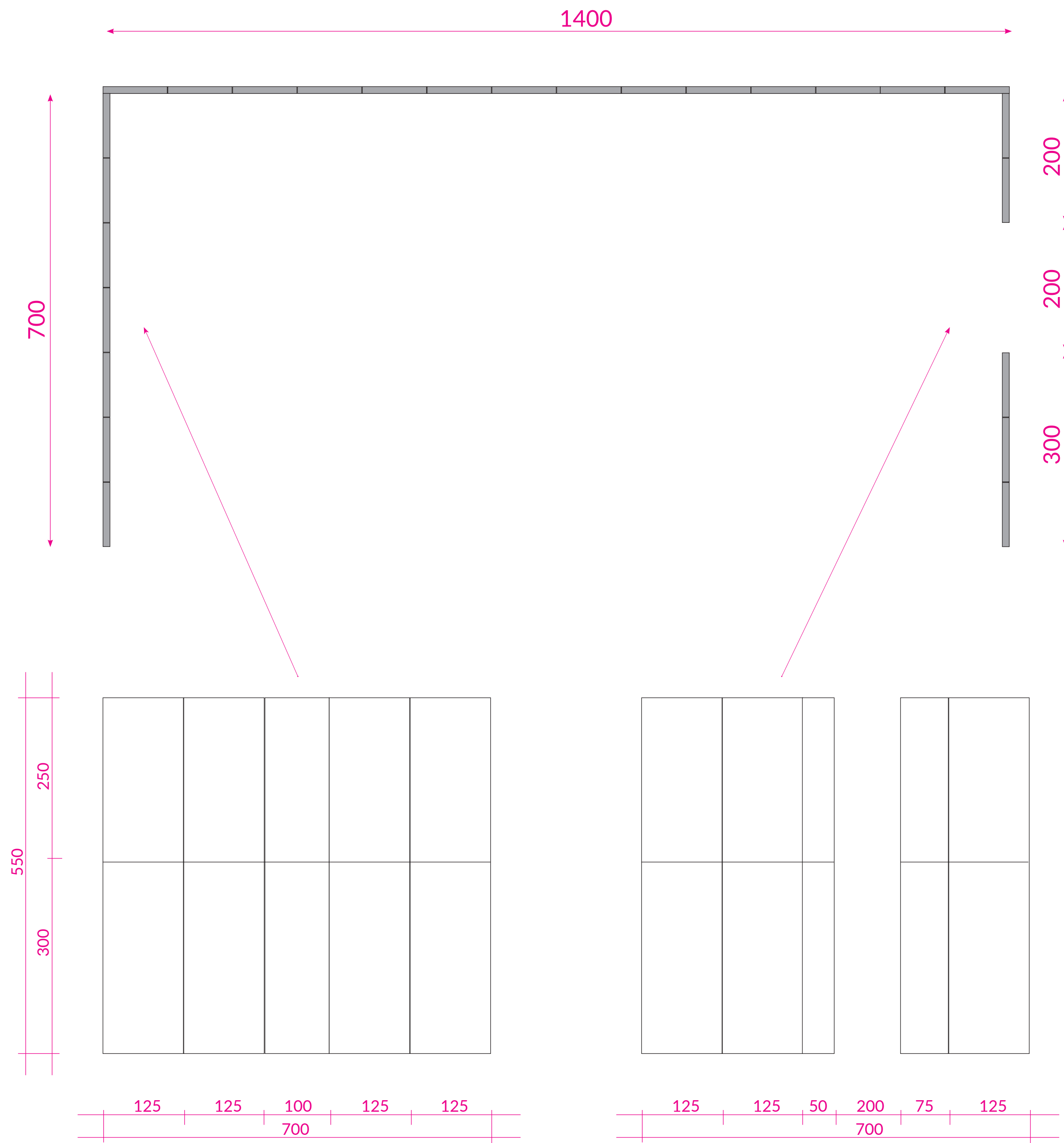

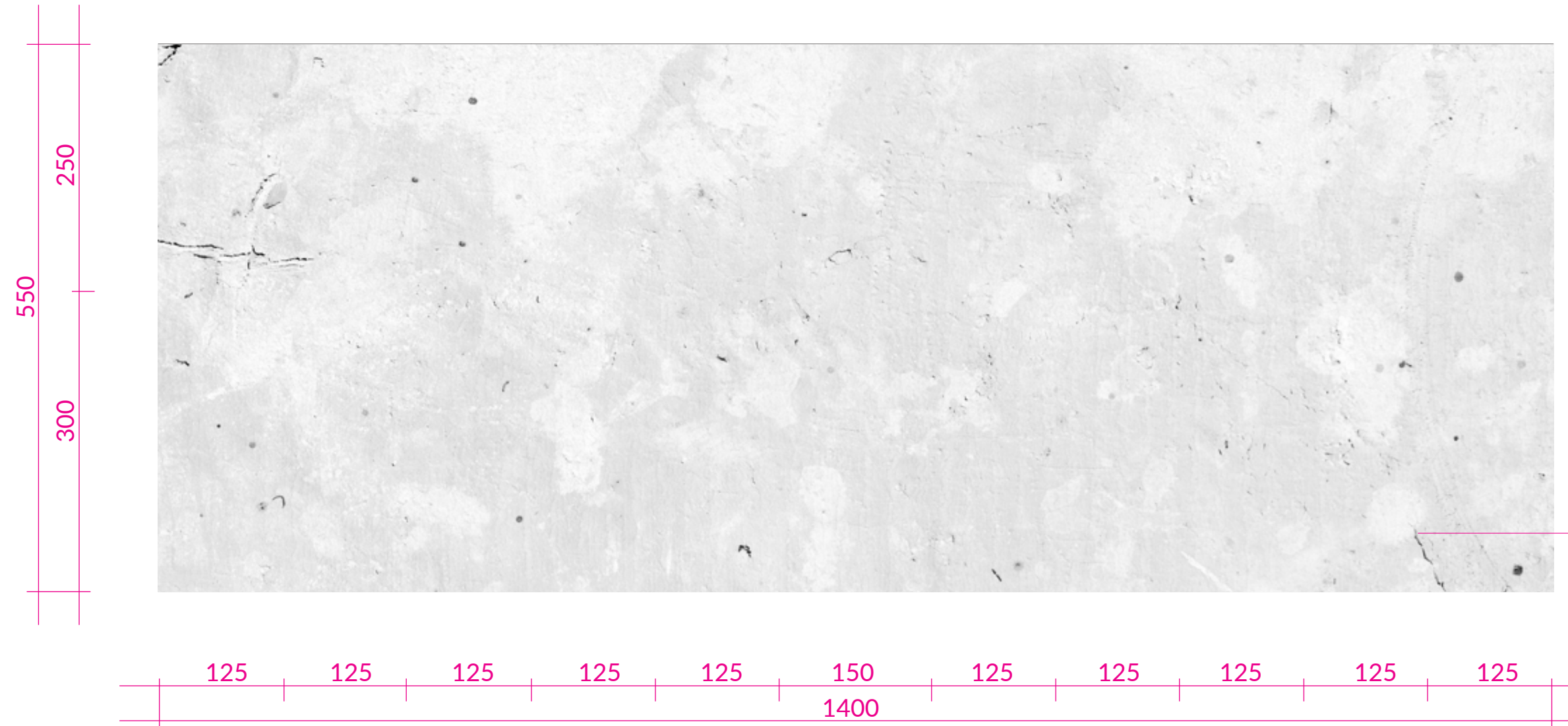

**ŚCIANY TYLNE**  
PODSTAWOWA STRUKTURA I WYBARWIENIE  
TAKIE SAMO JAK W ŚCIANIE MOBILNEJ

